

Position Indicator Unit

Type ULS52H, ULS52V, ULS54H

Publication Number: PB125/0517

Description

ULS52's 7 rows x 10 columns, 5.0mm dots, 51mm high. Horizontal or vertical PCB orientation.
ULS54's 7 rows x 20 columns, 5.0mm dots, 51mm high. Horizontal PCB orientation.

Application

The indicator units come in a choice of three colours - red, amber and green.

Parallel indicator units do not require an encoder board in the machine room. There are ten photo-coupled trigger inputs, connector PAR1, with one common return. These inputs are programmable to correspond to the respective floor legend. Signals are from 12V to 24V a.c./d.c. @ 20mA.

Serial indicator units require a separate encoder board which is mounted in the machine room and will interface directly to the lift controllers signal output. The encoder will convert all the required signals to a serial format and transmit these signals to all the indicator display units using 4 wire serial communication. The input connector for the serial interface on the display is SER. A total of 31 display units can be connected to a single encoder board. There is no special cable requirements for the 4 wire serial communication.

The ULS52's can display up to 2 characters or one character with a directional arrow. 2 character with override arrow is also available. The displays can also be programmed for vertical mounting.

The ULS54's can display up to three characters or two characters and a directional arrow.

Both have a flashing and/or scrolling facility for the arrows. If required, messages can also be programmed which will scroll in the same orientation as the PCB.

Note:

This component can be used to meet M2/S2* Building Regulations when a car position indicator, type ULS54S/P, is required.

Operation

The displays require 12V to 24V a.c./d.c. power supply. The maximum current consumption is less than 0.46A at 12V d.c. for ULS52 and 0.56A for ULS54. Connector SER is for the power supply inputs.

The displays are made up of either two (ULS52) or four (ULS54) high resolution block matrix LED displays which provide a clear, bright, wide angle view, even in sunlight.

Each unit is programmed to meet your specific requirement, just advise us of the legends you wish to be displayed.

When the lift is operating normally, the left-hand side of the display will show the directional arrow followed by a floor legend.

For parallel displays, the trigger signals to display the floor legend and arrows from the lift controller are accepted by the controller board causing the legends to be displayed together with the directional arrow. EEPROMS are programmed into each display unit to customise the unit before installing it into the lift.

For serial displays, the trigger signals to display the floor number and arrows from the lift controller are accepted by the encoder board in the lift machine room and transmitted to all the display units through the 4 wire serial interface. For the technical detail of the input signals please refer to the encoder board CX-Basic & CX-Synchro documentation.

Floor Position Indicator Control - floor inputs are driven by binary code, gray code, any arbitrary code or one per floor inputs.

Directional Arrow and Gong Control - (the gong is supplied as an option and applies to serial units only) - an input each for UP and DOWN arrow together with optional flash and scroll features if required. When these signals are present the directional arrow will flash and/or scroll. In addition, a lift stop signal is required to stop the arrow from scrolling when the car stops at a floor. If the floor number setting on the Switch SW1 matches the floor position code, the stationary arrow will flash to simulate a lantern, the gong outputs will activate gong.

Display Capabilities

The table overleaf details the maximum number of characters that can be programmed and triggered into the display.

EEC Directives

This component has been designed with due consideration to both BSEN81 parts 1 & 2 and the EMC Regulation BSEN12015 and BSEN12016 for incorporation in a lift application.

- *M2 - The Building Regulations 1991 Access and Facilities for Disabled People. Access and Use M2 (England and Wales).
- S2 - Technical Standards (Building Regulations) Part S : Access and Movement within Buildings, and Protective Barriers. Movement within Buildings S2 (Scotland).

FEATURES AVAILABLE SERIAL DISPLAYS	TERMINAL ALLOCATION (used with Serial displays only)	
	CX-Basic 24 MAX*	CX-Basic+Synchro 40 MAX**
UP & DN Arrows	2	
Scrolling Arrows	1	
Flashing Arrows	1	
Floors: Encoded	1-3	2
	1-7	3
	1-15	4
	1-31	5
One per floor: (discrete)		
With CX-Basic only	1-14	1 each
With CX-Basi+Synchro	1-30	
Message triggers:	1 each	

FEATURES AVAILABLE PARALLEL DISPLAYS	TERMINAL ALLOCATION (10 AVAILABLE)	
UP & DN Arrows	2	
Scrolling Arrows	1	
Flashing Arrows	1	
Floors: Encoded	1-3	2
	1-7	3
	1-15	4
	1-31	5
One per floor 1-10		1 each
Message triggers:	1 each	

* CX-Basic available inputs are reduced by 10 (dedicated inputs) for lantern, arrow, gong and speech control.

** CX-Basic+Synchro available inputs are reduced by 10 (dedicated inputs) for lantern, arrow, gong and speech control.

Construction

The UL52's and UL54's are constructed from two boards, as shown in the drawings below. There are four mounting holes for 4mm diameter screws that allow the display unit to be mounted to the faceplate. A window and plastic standoffs are provided with the display units.

Specification

	ULS52HS ULS52VS	ULS54HS	ULS52HP ULS52VP	ULS54HP
Input Signal	Four wires serial communication	Four wires serial communication	10 programmable photo-coupled inputs	10 programmable photo-coupled inputs
Display screen size	76mm (W) x 53.4mm (H)	152mm (W) x 53.4mm (H)	76mm (W) x 53.4mm (H)	152mm (W) x 53.4mm (H)
Physical PCB size	122mm (W) x 45mm (H) x 46mm (D) H 59mm (W) x 122mm (H) x 46mm (D) V	182mm (W) x 45mm (H) x 46mm (D)	122mm (W) x 45mm (H) x 46mm (D) H 59mm (W) x 122mm (H) x 46mm (D) V	182mm (W) x 45mm (H) x 46mm (D)
Number of LED dots	7 rows x 10 columns	7 rows by 20 columns	7 rows x 10 columns	7 rows by 20 columns
Dot size	5.0mm diameter	5.0mm diameter	5.0mm diameter	5.0mm diameter
Dot pitch	7.62mm	7.62mm	7.62mm	7.62mm
Character height	51mm	51mm	51mm	51mm
Colour	Single (red, green or amber)	Single (red, green or amber)	Single (red, green or amber)	Single (red, green or amber)
Operating temperature	-20°C to +65°C	-20°C to +65°C	-20°C to +65°C	-20°C to +65°C
Storage temperature	-20°C to +75°C	-20°C to +75°C	-20°C to +75°C	-20°C to +75°C
Humidity	0% to 95% non-condensing	0% to 95% non-condensing	0% to 95% non-condensing	0% to 95% non-condensing
Power supply, absolute max rating	10Vd.c. to 30Vd.c. or 10Va.c. to 27V a.c.	10Vd.c. to 30Vd.c. or 10Va.c. to 27V a.c.	10Vd.c. to 30Vd.c. or 10Va.c. to 27V a.c.	10Vd.c. to 30Vd.c. or 10Va.c. to 27V a.c.
Peak supply current (d.c.)	0.46A @ 12V, 0.23A @ 24V	0.56A @ 12V, 0.25A @ 24V	0.46A @ 12V, 0.23A @ 24V	0.56A @ 12V, 0.25A @ 24V
	Serial data is transmitted in blocks to the display unit. Each logical block defines a floor number and direction arrow. The floor codes and floor legends are stored in the encoder cards EPROM.		The floor codes and floor legends are stored in the displays EEPROM. Configuration and customisation is carried out by programming and replacing an EEPROM in the display unit.	

ULS52HP

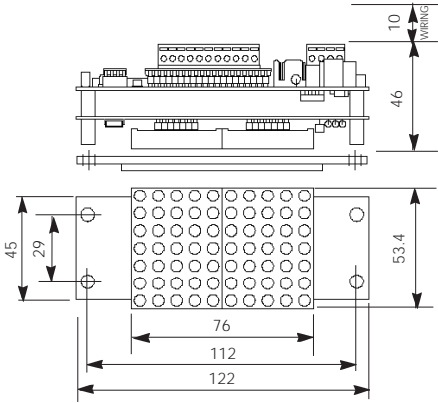

ULS52HS

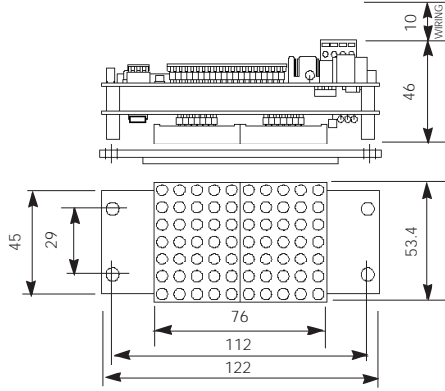

ULS52VP

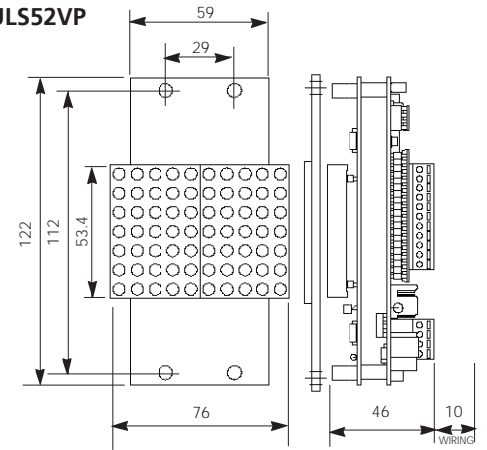

ULS52VS

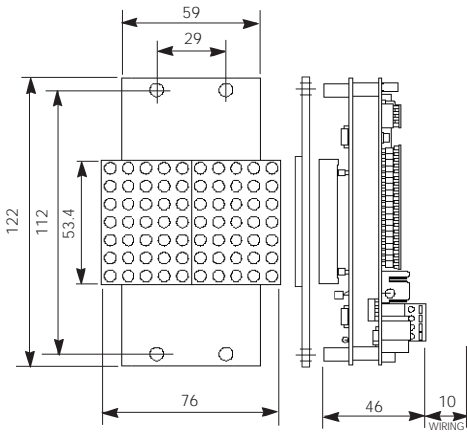

ULS54HP

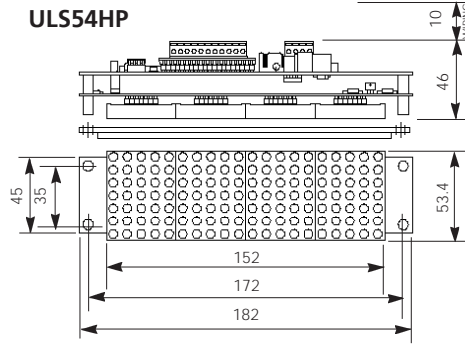

ULS54HS

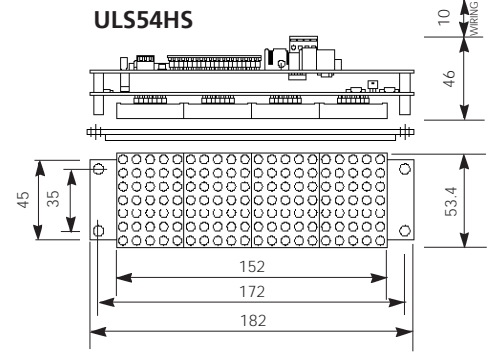

All dimensions in mm

ULS52 HORIZONTAL CUTOUTS

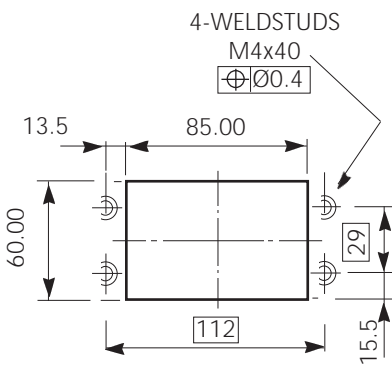

ULS52 VERTICAL CUT-OUTS

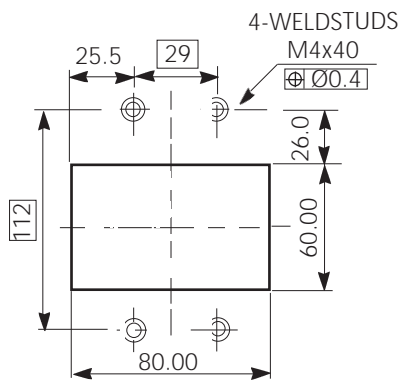

ULS54 HORIZONTAL CUTOUTS

